

Proposal for an Integrated MMW Radar System for Outdoor Navigation

Dirk Langer

CMU-RI-TR-96-15

The Robotics Institute
Carnegie Mellon University
5000 Forbes Avenue
Pittsburgh, PA 15213

10 March 1996

©1996 Carnegie Mellon University

This research is supported by TACOM in contract DAAE07-90-C-R059, 'CMU Autonomous Ground Vehicle' and US DOT in agreement DTFH61-94-X-00001, 'Automated Highway System'.

The views and conclusions expressed in this document are those of the author and should not be interpreted as representing the official policies, either express or implied, of the US government.

Abstract

[Note: This technical report is mostly my unchanged thesis document, except for section 2.4, an updated section 7 and appendix B.]

The design of a MMW radar sensor for mobile robot outdoor navigation is presented, that is able to operate robustly even under adverse weather conditions. This sensor has a range of approximately 200 metres and uses a linear array of receivers and wavefront reconstruction techniques to compute range and bearing of objects within the field of view. Currently, sensor design and hardware fabrication have been completed and the sensor is being integrated with other vehicle systems. Signal processing techniques are discussed and results obtained from simulation and the real sensor are presented.

Clutter rejection and the ability to classify and differentiate between objects will be improved in addition by integration of the radar data with information from a road geometry perception system. Road geometry perception will be based either on lane marker detection through a video camera or a digital road map.

The integrated sensor system can operate as a copilot for a human driver for speed control with respect to traffic density and as a safety monitor for lane changing. In addition it will be able to interact with other modules such as road followers and higher level planners for complete autonomous driving.

Table of Contents

1	Introduction	1
1.1	Sensor Systems Overview.....	1
1.2	Ganesha Overview	2
1.3	Previous work	2
2	Sensor Design Concept.....	3
2.1	Geometry.....	3
2.2	Radar Specifications.....	4
2.3	Data Processing.....	5
2.4	Preliminary Results.....	8
2.5	Local Target Grid Map.....	8
3	Integration with Road Geometry System	10
3.1	Problem Situations.....	10
3.2	Map based Solution.....	10
3.3	Vision based Solution	11
4	Vehicle Velocity Control.....	12
5	Research Agenda.....	13
6	Contributions	13
7	Schedule.....	14
	References	14
	Appendix A (Radar Block Diagram).....	15
	Appendix B (Technical Specifications)	16
	Appendix C (Sensor Geometry)	17

List of Figures

Figure 1	Sensor Geometry	3
Figure 2	Area coverage in horizontal.....	4
Figure 3	Radar Simulation of targets	6
Figure 4	Resolution limit of Fourier Transform	7
Figure 5	Power Spectral Density for 32 complex data points	7
Figure 6	Radar Data obtained on Highway.....	8
Figure 7	Local Grid Map	9
Figure 8	Traffic situations leading to potential false alarms.....	10
Figure 9	Digital Map of Urban Area (in Pittsburgh)	11
Figure 10	Typical road scene with extracted lane geometry	12
Figure 11	Steering Arc Evaluation	12
	FMCW Radar Block Diagram (Appendix A).....	15
	Minimum Turn Radius (Appendix C).....	17
	Maximum road gradient (Appendix C).....	18
	Geometric Analysis of different traffic scenarios (Appendix C).....	18

1 Introduction

Collision Avoidance and the detection of objects in the environment is an important task for an autonomous mobile vehicle. So far, robots have mostly used sonar and short range laser based sensors. The GANESHA system has demonstrated the use of these sensors to accomplish these navigational tasks at low speeds. However, the perception capabilities of GANESHA are inadequate for autonomous driving at higher speeds, both on road and cross-country. Some perception systems have been developed, based on laser, radar or CCD cameras, to provide a longer range sensing capability and detect obstacles. However, to date none of these systems has demonstrated the ability to operate robustly under all weather conditions and return all the necessary geometric information about potential collision targets and safe driving directions. Problems especially still persist in cluttered environments, such as country or city roads with oncoming traffic. My thesis research therefore proposes the following:

1. To build a robust, all weather, long range sensor with crude imaging capabilities.
2. To integrate the sensor with geometric road information and vehicle state (turn arc and velocity) for an improved driving system.

I will demonstrate new capabilities with the GANESHA navigation system, through the development of a superior perception system and using the CMU Navlab vehicles. These capabilities will include the detection of on-road obstacles including people under all weather conditions, safety monitor for lane changing and speed control with respect to traffic density.

1.1 Sensor Systems Overview

In the context of a robot automobile driving at moderate or high speeds, a sensor with a fairly long range is needed. The proposed sensor system is designed such that it could operate in environments with the following geometry:

Multilane roads with other vehicles such as lorries, cars, motorcycles. Pedestrians are assumed to be present only in an environment where vehicles move relatively slow.

Therefore the sensor should fulfill the following requirements:

- Maximum range between 100 and 300 metres
- Can operate under adverse weather conditions (rain, snow).
- Can operate at night and when visibility is poor (fog).
- Data rate should be about 10 Hz.
- Longitudinal resolution between 0.1 and 1 m.
- Lateral resolution must be able to discriminate between vehicles in different lanes for Highway scenario.
- Preferably no mechanically moving parts.
- Safe operation in environments where humans are present.
- No interference between different sensors.

Keeping the above requirements in mind, it was decided to choose a radar based sensor system. There are also other potential candidates available for the sensor requirements described which are based on different physical principles. However, they have the following disadvantages for the application as compared to a radar based system:

Stereo or other video camera vision based methods do not work well at night in general as they depend on an external source for illumination. Owing to the structure of a CCD, they have good lateral resolution, but a good longitudinal resolution can only be achieved at relatively high computational costs. The footprint of a pixel and size of the CCD are among the factors that determine maximum range and accuracy. In order to get good resolution at long ranges, the baseline needs to be wide which is limited by the width of the vehicle and the required overlap

between the stereo images. Another problem in stereo is the need to mount the stereo rig rigidly on the vehicle to avoid calibration errors. The wider the baseline, the more problematic is a rigid mount. In terms of size, current stereo sensors also require a relatively large volume in space for mounting and computing.

Laser sensors are also light based sensors. Since they emit laser light actively, they also work at night. Compared to a radar sensor, they are able to resolve smaller objects due to the smaller wavelength. However, they suffer from errors due to reflection problems from dark surfaces or mirror like and transparent surfaces. Laser beams also have a much sharper drop off at the 3 dB beam angle width which leads to a much narrower effective beam width. A laser sensor might therefore miss a target in the vehicle's own lane at long ranges.

Both, stereo and laser based sensors have problems working under adverse weather conditions especially when visibility is reduced since they both work at visible or near visible light wavelengths. A radar sensor exhibits much better characteristics under these conditions.

1.2 GANESHA Overview

In order to further process the sensor range data and make it available for higher level interpretation modules, the data needs to be position tagged and stored in a map. GANESHA (*Grid based Approach for Navigation by Evidence Storage and Histogram Analysis*) is a system using sonar or the ERIM laser range camera that we implemented for the autonomous land vehicle Navlab. The system builds a local grid map of its environment from the sensor data. The map raw data is filtered in several steps. The information collected in the map can then be used for a variety of applications in vehicle navigation like collision avoidance, feature tracking and parking. An algorithm was implemented that can track a static feature such as a rail, wall or an array of parked cars and use this information to drive the vehicle. In tracking mode, steering commands are generated using the pure pursuit method. In obstacle avoidance mode a set of turn arcs is evaluated for potential collisions with obstacles. Steering commands are generated by selecting a permitted turn arc in the desired direction.

GANESHA has demonstrated its ability to autonomously drive a vehicle, search for a parking gap and parallel park the vehicle [8]. It has also shown its ability to aid in navigation through a cross-country environment [7].

1.3 Previous work

In the last 10 years several sensor systems have been developed for collision avoidance in automobiles using different approaches. Mercedes-Benz and Dickmanns/Graefe et al equipped their vehicles with video cameras for road following and obstacle sensing. Other automobiles and their range are detected from a single video image using a car model and relative size of the object in the image. Recently their test vehicle was equipped with 18 video cameras looking in all directions. This way also objects on the side and coming up from behind are sensed.

Leica has developed an infrared laser range system. The multibeam version (MSAR Odin) uses five beams and covers a total Horizontal Field of View (HFoV) of 7.5° with a max. range of 150 m. Mercedes-Benz equipped one of the *Prometheus* vehicles with this sensor and integrated it into an intelligent cruise control. When traveling through a bend, the system uses steering angle information to focus on objects detected by the outermost sensor beams and filter stationary objects.

A simplified single beam version (Odin II) has a HFoV of 3° with an operating range of 20 to 80 m. Distance accuracy is about 3 m.

Several automotive and electronics companies have developed radar based systems for intelligent cruise control and collision avoidance applications (Mercedes-Benz, Vorad, Millitech, TRW, Delco, Toyota, GEC Plessey, Phillips, etc.). Most of these systems use a single narrow beam sensor to detect other vehicles in the vehicles own driving lane. Millitech developed a pulsed three beam system with a total HFoV of 6° . The outer beams are used to distinguish between a strong target in an adjacent lane and a weak target in the vehicle's own lane. The Vorad radar uses the doppler range method. This means that a range measurement can only be obtained when there is relative movement between sensor and target. All of these sensors potentially have problems locating a target properly in curves.

At the Technical University Munich (TUM), an automotive radar with a 12° HFoV and an operating range of 20 to 100 m has been developed [10]. Range is obtained through binary phase coding with pseudo random noise and a range resolution of 0.75 m. This radar also returns directional information through wave front reconstruction with

multiple receivers.

2 Sensor Design Concept

This design is closely related to that of the TUM radar, as it appeared that this type of design would offer the best compromise in terms of capabilities and technological simplicity. However, our design includes some significant changes.

2.1 Geometry

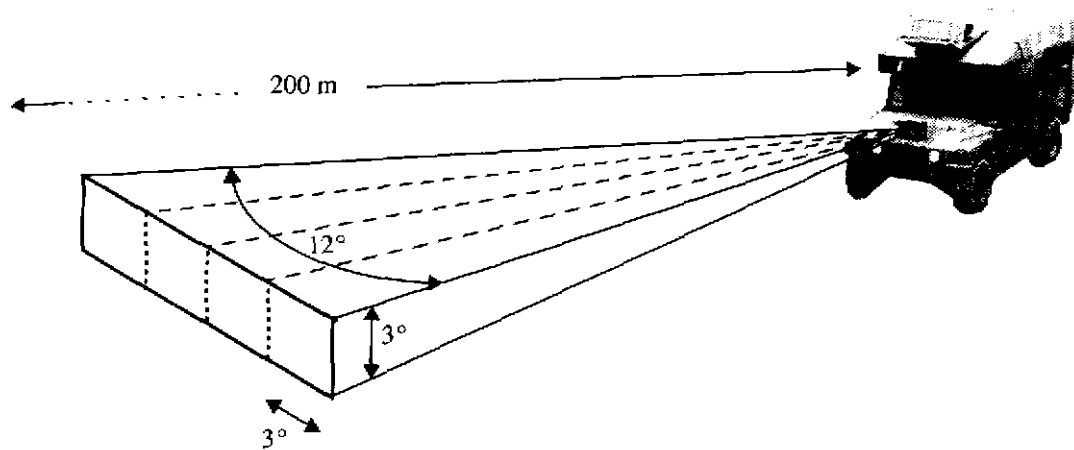

Figure 1 Sensor Geometry

The geometry of the proposed radar sensor is shown in Figure 1. A vertical field of view of 3° was chosen as it provides the best compromise between good obstacle coverage in the vertical direction and avoiding false measurements due to ground reflections and returns from road signs or other structures located overhead. At longer ranges the ground (road) will reflect specularly. The current design shows a horizontal field of view of 12° , which is divided into four or more angular resolution cells. Assuming an average highway lane width of 4 metres, the sensor will provide an area coverage in the horizontal plane as shown in Figure 2. One lane will be covered at a range of approximately 19 metres, three lanes will be covered at a range of 57 metres and five lanes at a range of 95 metres. A 3° angular resolution cell covers an entire lane width at a range of 76 metres.

It would have been preferable to use a larger horizontal field of view of up to 20° . However, for cost reasons in the antenna design we settled on the HFoV shown.

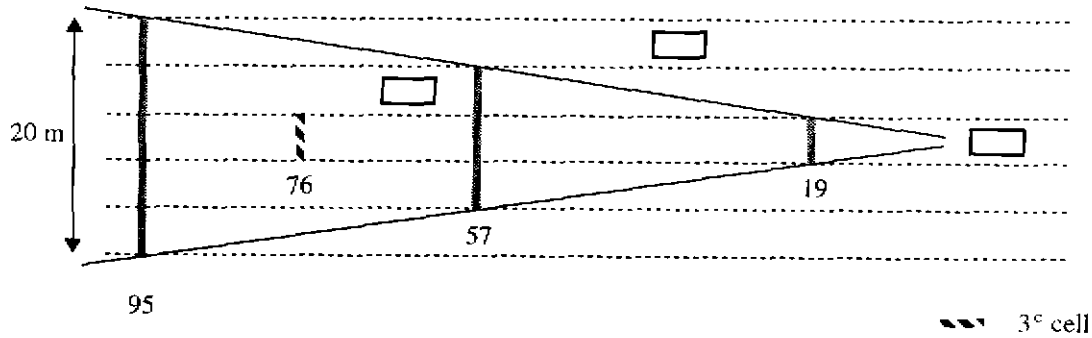

Figure 2 Area coverage in horizontal

In order to stop for a stationary object at highway speeds of 100 km/h (~ 65 mph) a detection distance of at least 55 metres would be needed (assuming $a = -7 \text{ m/s}^2$ and neglecting reaction time). Since in autonomous mode, the vehicle needs to react to objects moving at considerably different relative speeds, the maximum range of the sensor for detecting vehicles is designed to be about 200 metres. People have a much lower radar cross section ($0.2 - 2 \text{ m}^2$) as compared to vehicles (10 m^2) and can therefore be detected only at a much smaller maximum range. For the proposed sensor system, this would be about 60 metres. However, this does not pose a problem as people are assumed only to be present in a road environment where vehicles also move considerably slower, i.e. 50 km/h (~30 mph).

2.2 Radar Specifications

For simplicity of design and better sensitivity, it was decided to operate the radar as a Frequency Modulated Continuous Wave (FMCW) system. A block diagram of the design is shown in Appendix A. The carrier frequency is at 77 GHz. The corresponding wavelength will be in the mm-Range which results in better resolution of scene details than at lower frequencies. Also, above 30 GHz, reflection from vegetation and foliage is more significant. Attenuation at these frequencies is larger than at lower ones. However, this also keeps the maximum range of the radar relatively short and thus reduces interference. A carrier frequency in the millimeter wave range also allows larger frequency sweeps for better range resolution and limits interference with existing commercial radio frequency transmitters. Because the transmitted signal is spread over a large bandwidth, an FMCW radar is quite robust against interference from other sensors of the same type. Interference can be further reduced by using a coded FM wave form. For a simple radar system the maximum range resolution is related to the bandwidth by the following relation:

$$\delta R = \frac{c}{2B} \quad B = 2\Delta f \quad (1)$$

The frequency sweep $2\Delta f$ of the radar is 300 MHz, which therefore results in a range resolution of 0.5 m. For a maximum range of $R = 200 \text{ m}$ and a desired maximum intermediate frequency (IF) of $f_{IF} = 500 \text{ kHz}$, the modulation frequency f_m is given by equation (2) and is calculated to be 625 Hz for a triangular modulation and 1.25 kHz for a sawtooth modulation:

$$f_m = \frac{c \cdot f_{IF}}{8\Delta f R} \quad (\text{Bipolar Triangle}) \quad f_m = \frac{c \cdot f_{IF}}{4\Delta f R} \quad (\text{Sawtooth}) \quad (2)$$

If the FM waveform used is triangular, maximum unambiguous range is 1200 km and can be calculated from equation (3):

$$R_m = \frac{c}{2f_m} \quad (3)$$

In order to be able to detect vehicles and people within the given range, transmitter power of the radar system will be around 30 mW, as can be calculated from the *radar equation* (see [4], [3]).

Range and angular information of targets are obtained by Fast Fourier Transform (FFT) or similar spectral analysis methods as described in the following section.

2.3 Data Processing

The output of the mixers on the receiver channels of the radar sensor (see Appendix A) is a mixture of different frequencies. Each discrete frequency corresponds to range to a target. Therefore the range to a target can be obtained efficiently by using a FFT. The received signals are first passed through a high pass filter which acts as a range dependent gain, since signal frequency corresponds to range. The signals are then amplified and fed through a low pass filter at 500 kHz before being converted to digital. The low pass filter prevents errors due to aliasing effects in the succeeding FFTs.

Angular bearing and range to the target is obtained by digital wave front reconstruction and beam forming. This involves two consecutive FFTs along the time and space dimension of the signal. The space dimension is in this case the four receiver elements that are used to sample the incoming wave front at discrete points in space. The first FFT along the time dimension of the receiver output signal gives target range as mentioned above. The second FFT along the space dimension performs a cross correlation that is a measure of the time lag between the signals in each receiver channel. The maximum peak in the correlation indicates the time lag and thus the bearing of the incoming signal. A more detailed description of the method is given in [2] and [5]. Since the radar currently has four receivers, we obtain four angular resolution cells as shown in Figure 1. In order to determine target bearing unambiguously within the given sensor's field of view, the following condition for the receiver antenna spacings Δx_i needs to be obeyed:

$$\Delta x_i < \frac{1}{\sin(2\alpha_E)} \cdot \lambda \quad (4)$$

where $2\alpha_E = 12^\circ$ is the unambiguous range, i.e. the horizontal field of view.

The radar signal processing is shown in simulation for simulated targets at (50 m, 2°) and (150m, -5°) in Figure 3:

- (a) shows the overlaid time signal from the output of two of the four mixers. Note that the range information is contained in the frequency and the bearing information in the phase shift of the signals.
- (b) is the spectrum of the fourier transformed time signals for 1024 data points. The four spectra from the mixers are overlaid. The noise level at -350 [dB] is just numerical noise in channel 0. The noise level in channels 1-3 is much higher due to leakage effects in the FFT. In this simulation, we did not introduce any system noise but just used ideal signals.
- (c) shows a contour plot of the range vs. bearing matrix after the second FFT is applied along the spatial dimension. In the range dimension we used 256 data points. In the bearing dimension we used 64 bins. Since there are only four data points from the four receivers, the remaining bins are zero padded. The peaks indicating targets A and B can be seen at their expected locations.
- (d) is a cross-sectional cut through the range vs. bearing matrix at the calculated range for target A and target B. The difference in level between the main lobe and the first side lobe is 11.5 [dB] as predicted by theory [1].
- (e) shows a mesh plot of the same range vs. bearing matrix as in (c).

The simulation was implemented using the MATLAB software package.

The Fourier Transform is limited in resolution by the number of data points given. This means for the bearing dimension that one resolution cell is $12^\circ / 4 = 3^\circ$, since we have four receivers in the spatial dimension. Hence if two targets are at the same range, but their bearing is less than 3° apart, they cannot be resolved anymore and are merged into one target lobe. This situation is illustrated in Figure 4:

In (a), the targets are 3° apart and can just be resolved; In (b) the targets are less than 3° apart and cannot be resolved anymore.

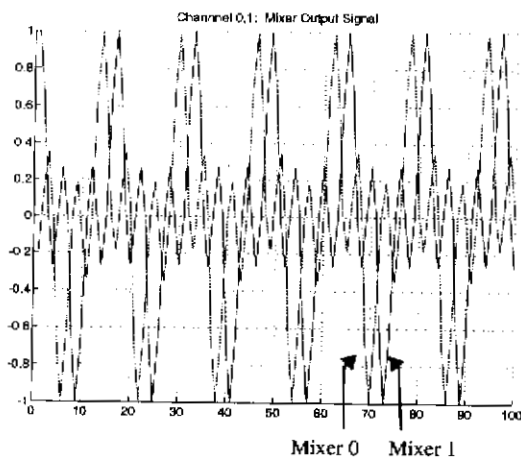

(a) Signal

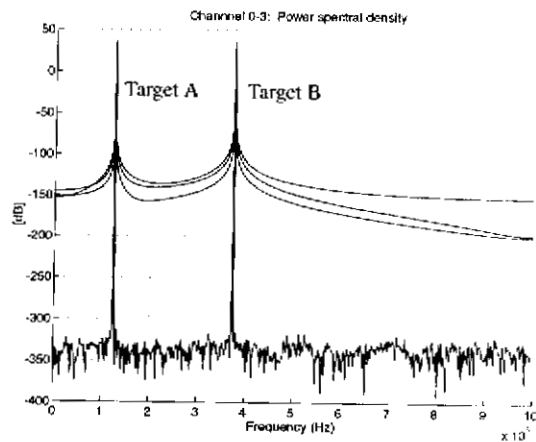

(b) Spectrum

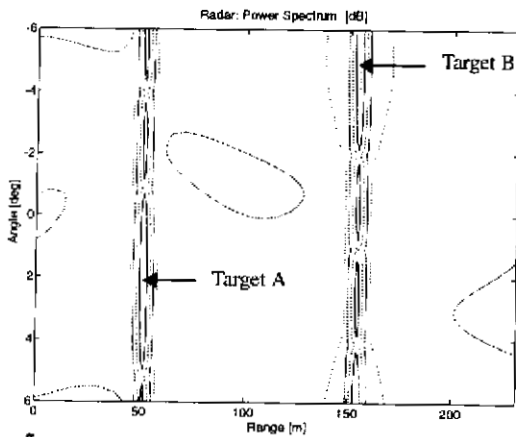

(c) Contour Plot of Range / Bearing Matrix

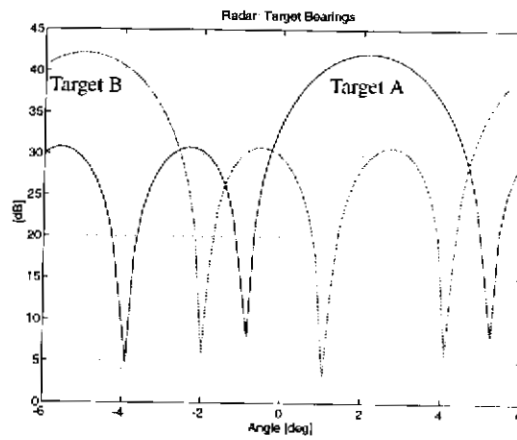

(d) Bearing versus Power

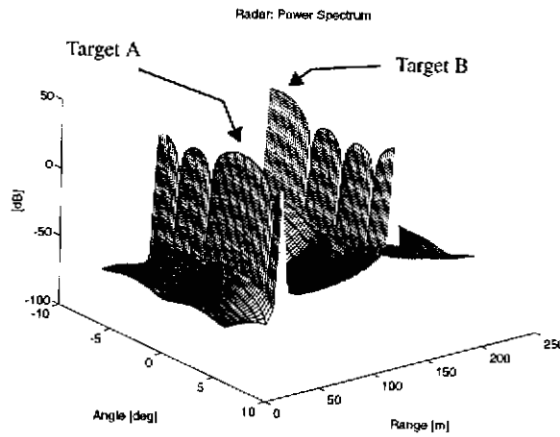

(e) Mesh Plot of Range vs. Bearing Matrix

Figure 3 Radar Simulation of targets at (50 m, 2°) and (150m, -5°)

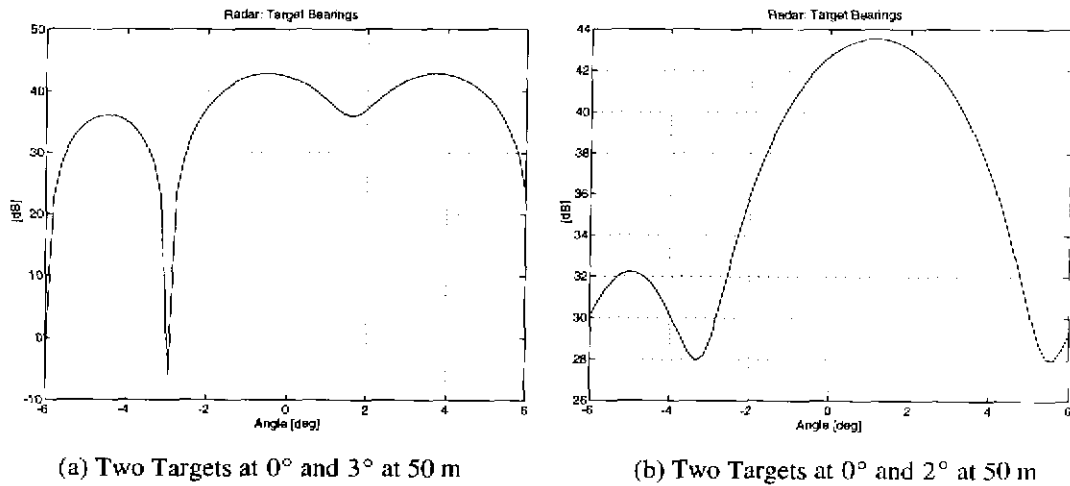

Figure 4 Resolution limit of Fourier Transform

This means that for certain environment geometries, resolution by using a FFT may be poor. Instead, better results could be obtained by using techniques for high resolution spectral analysis.

To illustrate possible improvements, Figure 5 shows results obtained from the two different methods when applied to a complex test signal. The test signal consists of sinusoidal components at $f_1 = 0.05$, $f_2 = 0.40$ and $f_3 = 0.42$ and zero mean white Gaussian noise. The true expected power spectral density of the test signal is shown in Figure 5a. Altogether 32 complex sample points of the test signal were generated and spectrally analysed with a FFT (Figure 5b) and the **Maximum Entropy Method** using the Burg algorithm (Figure 5c).

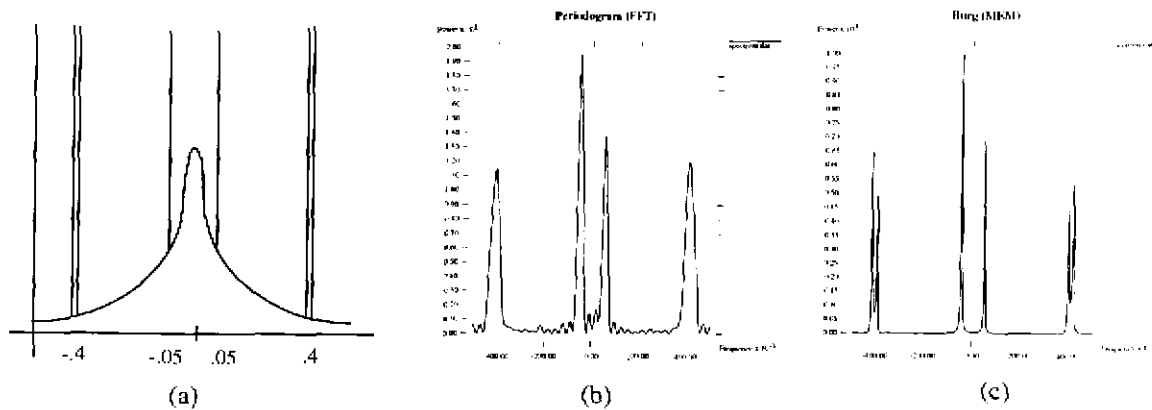

Figure 5 Power Spectral Density for 32 complex data points and 256 frequency samples:
 (a) True PSD, (b) Periodogram from FFT with zero padding,
 (c) Burg Algorithm (Maximum Entropy Method)

As can be seen in Figure 5, both methods can resolve frequency f_1 , but only MEM resolves f_2 and f_3 , whereas the FFT analysis shows only one peak in the spectrum for these two frequencies.

In the case of the FFT, resolution is determined by the number of data points that are input to the FFT algorithm. Here the resolution limit of the FFT is $1/32 \approx 0.03$. Accuracy, but not resolution, can be improved by zero padding.

An increased resolution is generally desirable as it leads to an improved Signal-to-Clutter S/C ratio. This improvement happens because ground and rain clutter generally fill an entire radar resolution cell, but the dimensions of a typical radar target are usually much smaller.

It should be noted that here resolution is the ability of the system to distinguish between two separate targets that are close together, whereas accuracy is the absolute accuracy with which a single target position can be determined.

A complex signal may be needed in order to resolve the directional ambiguities for the Doppler component of the signal. This can be obtained by either feeding the signal through a quadrature receiver or by using a Hilbert Transform on the real signal and thus obtain the imaginary part. A single channel receiver element in combination with a Hilbert Transform has the advantage that phase and amplitude errors that occur in a quadrature receiver do not have to be considered.

2.4 Preliminary Results

Figure 6 shows plots of range and bearing and the corresponding scene picture of real data obtained with the sensor on a highway. Note that the bearing data appears quite smooth because only 4 data points are available.

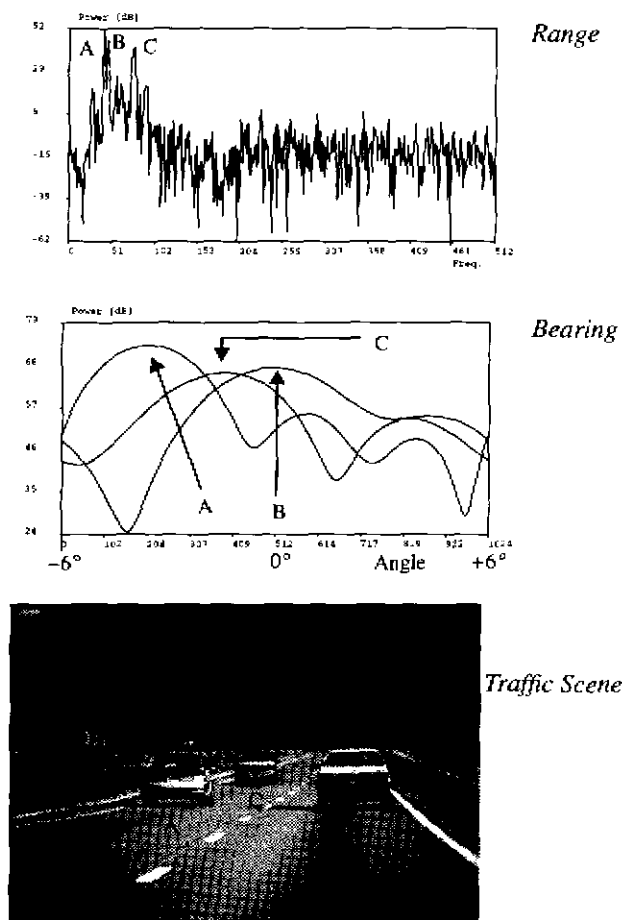

Figure 6 Radar Data obtained on Highway

2.5 Local Target Grid Map

The data obtained from the sensor can now be used to build a local grid map. The grid map is local because it contains only information about the immediate surroundings of the vehicle. The vehicle position is kept at a fixed point in the map. As the vehicle moves, objects in the map are moved from cell to cell relative to vehicle position.

Once an object falls outside the map boundary it is discarded and the information is lost. The map covers the sensor's field of view, using a variable resolution along x-axis and y-axis. In all, the map consists of 41×101 cells. As objects get further away from the vehicle, a coarser map resolution is adequate, since sensor readings become less accurate. However, coarse resolution map information is sufficient to plan initial navigation manoeuvres and perform target discrimination. As the object moves closer, navigation needs to be more precise and therefore map resolution is increased. (See Figure 7).

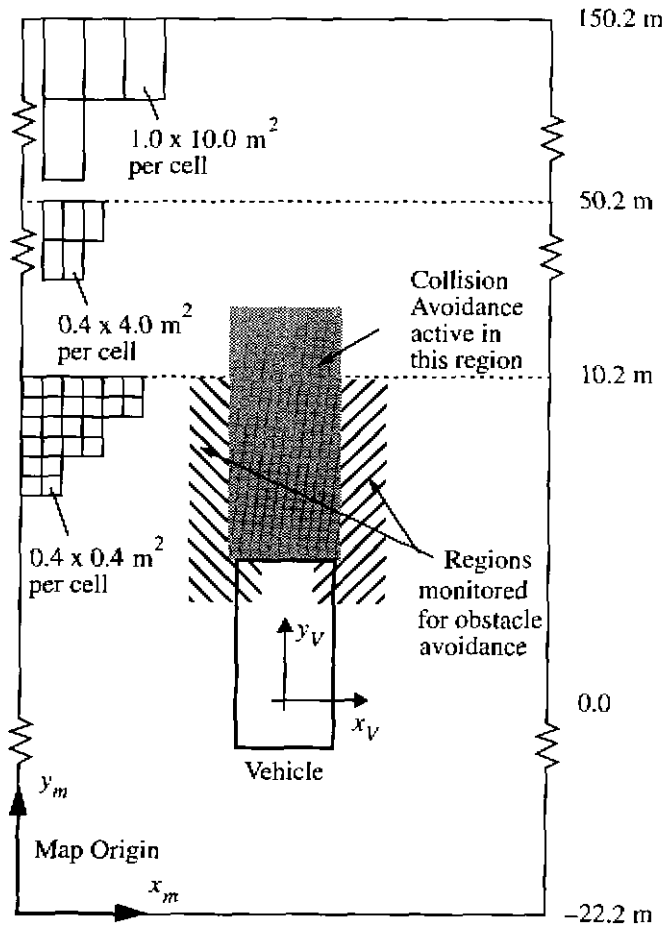

Figure 7 Local Grid Map

Each cell has a set of parameters or annotations associated with it, which are described below:

1. **Object Type**
 This parameter is used to indicate if the object in that cell was seen at the current sensor reading, or if it was seen at a previous reading. If it was seen only at a previous reading, then the object type indicates that it must have moved to that particular cell due to vehicle motion only.
 The parameter is also used to denote which type of sensor detected that particular object if several different types of sensors are connected (e.g. sonar or radar).
2. **Position**
 Indicates the x-y position of the object with respect to vehicle position.
3. **Velocity**
 Indicates the relative velocity of the object towards the vehicle (Doppler velocity).

4. **History**

This parameter counts the number of times an object was detected in a particular cell.

5. **Curvature Vector**

Is precomputed for each cell and denotes the range of steering arcs that would avoid a collision between the vehicle and an object in that cell.

The resolution of the grid is fairly coarse and hence a position parameter (X_{obj}, Y_{obj}) is kept to avoid gross error accumulation when objects are transformed in the map. Only one object is kept per grid cell.

Measurement uncertainty is part of the grid cell representation and any object detected within an area covered by a particular cell is taken to belong to the same object.

3 Integration with Road Geometry System

3.1 Problem Situations

In certain road environments, a false alarm situation may potentially arise. This is especially the case for multilane roads, undivided highways, curved roads and roads that are bordered by stationary objects such as guard rails or trees.

It is therefore important to have some information about the road geometry the vehicle is driving in. On a straight stretch of road, assignment of obstacles to particular lanes and areas off road and on road is simple. On undivided roads it is, however, important to know whether an object in front of the vehicle is in the vehicles own driving lane or in the lane for oncoming traffic or off road. If the road is curved then an additional difficulty is to determine whether an object is in a neighbouring lane on a multilane road or the oncoming traffic lane or off road. Typical traffic situations are shown in Figure 8. A more detailed analysis of the geometry is given in Appendix C.

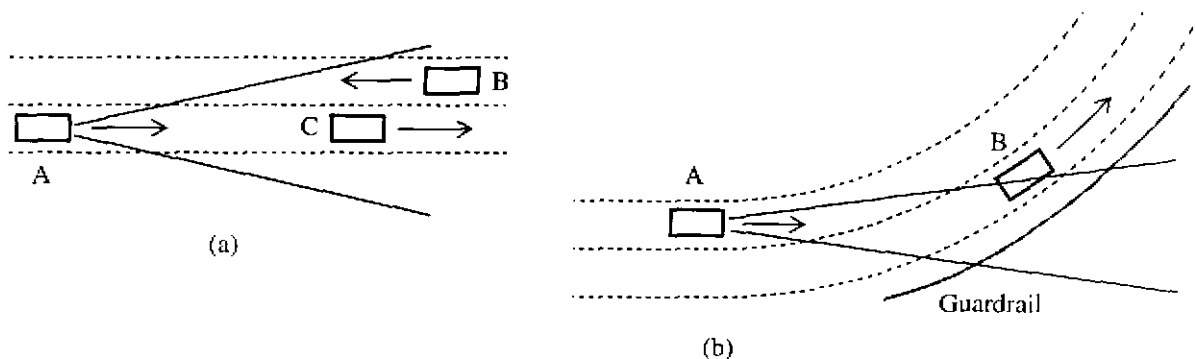

Figure 8 Traffic situations leading to potential false alarms

In Figure 8b for example, vehicle A detects two targets ahead: vehicle A and a portion of the guardrail. It is obvious that neither object poses a threat if vehicle A stays in its current driving lane. However, a radar only based sensor system will not be able to assess this situation properly without additional information about road geometry.

As a first step, information about steering radius from a steering encoder can be integrated. This will help to reject clutter and improve performance when the vehicle is driving through a bend. However, since in this case we only know the current vehicle state but cannot look ahead, the traffic situation in Figure 8b still poses a problem. Here the vehicle is still on a straight stretch of road and does not know yet of the curve ahead.

In the following sections, we will therefore describe two approaches for integrating additional information.

3.2 Map based Solution

With the advance of technology in recent years, digital maps of many urban and non-urban areas in the country

have become available. Currently the best available resolution is approximately 12 metres. A typical map of this kind is shown in Figure 9.

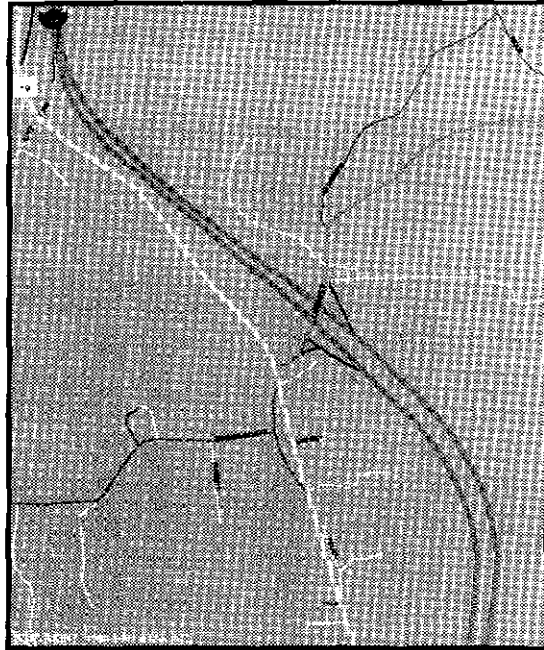

Figure 9 Digital Map of Urban Area (in Pittsburgh)

Different types of roads are shown. Each road is split into segments, represented by a small number of position data points. By integrating such a map with a Global Positioning System (GPS), the position of the vehicle on the map can be determined. With the given map resolution, individual lanes on a particular road cannot be distinguished, but it is possible to look ahead and detect approaching curves and their curvature. Also, information on road structure, such as the number of lanes, lane widths, divided highway, etc., can be easily added. Then, if we know in which lane the vehicle is currently driving, it will be possible to match targets appropriately and distinguish between targets in different lanes and on road / off road targets.

It should be mentioned here that other research projects on autonomous vehicle control use buried lane markers that are sensed inductively (PATH project). These could potentially also carry coded lane information. This method could be considered as another option, but will not be a focus in the proposed research.

3.3 Vision based Solution

Several vision systems using CCD cameras have been developed that can provide information about road geometry. Two different approaches have been taken so far: One is road model based [6], whereas the other is neural network based [9]. Both systems are able to provide lane edge and centre positions.

Figure 10 shows a typical road scene as seen by a camera. Targets detected by the radar system then have to be matched to the road geometry as detected by a calibrated vision system. This can be efficiently done by using a local grid map as a database. A framework that can be used for this purpose is described in section 2.5 (See also [8]). This information can then be used as input to higher level navigation functions for autonomous driving in traffic.

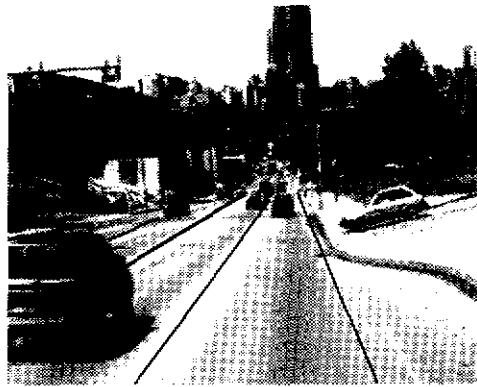

Figure 10 Typical road scene with extracted lane geometry

4 Vehicle Velocity Control

The information contained in the local target grid map, integrated from radar and road geometry data, can now be used to control the vehicle velocity at a safe level. As mentioned in section 2.5, each cell of the grid map also carries precomputed information about the range of inhibited steering arcs if an obstacle would occupy that particular cell. In addition, we also know the length of arc that the vehicle would need to travel before colliding with an obstacle in a particular map cell.

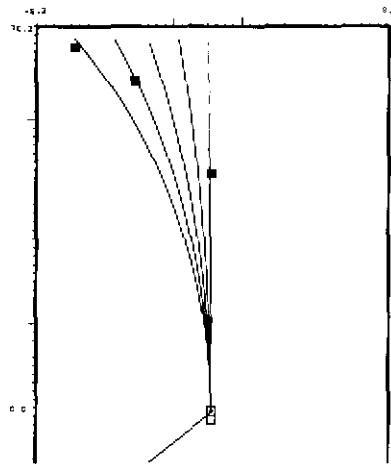

Figure 11 Steering Arc Evaluation

When moving through a cluttered environment, the velocity of the vehicle can now be controlled depending on distance to surrounding objects, current vehicle driving direction and geometry of the environment. In addition, information can be provided on whether it is safe to initiate an overtaking manoeuvre. This is especially useful on a two lane road with oncoming traffic. Figure 11 shows the evaluation of a subset of steering arcs with respect to obstacles in the local grid map.

5 Research Agenda

The proposed research falls into the following areas:

1. Design and development of the millimeter wave radar sensor.
2. Refinement of the radar sensor's resolution ability with high resolution spectral estimation techniques.
 - Standard FFT, Maximum Entropy and Prony Method.
3. Integration with a road geometry system, based on a digital road map or lane marker detection through a video camera.
4. Target mapping and classification based on target properties such as signal strength, location and doppler velocity.
 - Clutter rejection
 - Differentiation between on-road and off-road targets such as guardrail, trees, telephone poles.
5. Integrating velocity control and providing driver information for several traffic scenarios:
 - All road types: Detection of static and moving objects using doppler and range information. Mapping of targets to road lanes and off road objects. Ability to detect people and animals up to 60 m.
 - Multilane divided highway: Tracking vehicles in driving lane and adjacent lanes.
 - Two lane rural road: Detection of oncoming traffic in opposite lane. (At long ranges, a vehicle in the opposite lane and a vehicle in the driving lane in front will both fall in the same angular resolution cell.) Provide information to driver whether a safe overtaking manoeuvre is possible, based on vehicle velocities and ranges.
 - City roads: Stop and go traffic. People crossing road.
6. System performance evaluation for each of the above sections and demonstration on Navlab vehicles.
 - Performance evaluation will be based on the number of false positive and negative alarms for a given real world scenario in a controlled environment. This metric also serves as an improvement measure between a bare bones system and a system with the proposed additional capabilities.

6 Contributions

The goal is to develop a sensing system capable of providing relevant information about the local traffic situation to an intelligent cruise control (ICC) or a human driver. The core of this system will be an integrated radar sensor linked to a road geometry database. It will demonstrate techniques for radar target classification and clutter rejection. As an improvement over current systems, it will be able to operate on a highway as well as more cluttered environments such as rural or city roads. At the moment, rural road accidents cause the largest number of fatalities and the largest total number of accidents occurs in city traffic.

The proposed radar sensor design will demonstrate the ability to achieve high resolution target position detection with a minimal amount of hardware and no mechanical scanning mechanism. Most other existing sensor design prototypes are restricted in their field of view and resolution as they use a limited number of discrete multiple beams.

The result of this thesis research will be a better driving system which will be achieved by integrating an improved radar sensor with road geometry information.

7 Schedule

1995	Jan	Write Thesis Proposal
	Feb	Proposal. Build and debug A/D and interface part of radar.
	Mar	Test and delivery of radar front end from Millitech.
	Apr	Integrate Radar components and Power system.
	May	Implement processing by FFT.
	Jun	Lab Demo at Demo B. Implement processing by high resolution spectral
	Jul	estimation techniques
	Aug	Test and calibrate sensor.
Sept		
Oct		
1996	Nov	On road experiments and further tests.
	Dec	
	Jan	Integrate C40 DSP Hardware.
	Feb	
	Mar	
	Apr	Implement High Resolution Spectral Estimation Techniques.
	May	Start writing thesis.
	June	
July	Integrate Road geometry system.	
Aug		
Sept		
Oct	Defend	

References

- [1] M. Bockmair. *Mikrowellenabbildung im Nahbereich*. Phd Dissertation, Technische Universitaet Muenchen, 1989.
- [2] P. Cao, J. Cuschieri and R. Sudhakar. A High Resolution 3-D Sonar Imaging System For Autonomous Underwater Vehicles. In *Proc. of Oceans '91*. Honolulu, HI. October 1991.
- [3] N. Currie, C. Brown. *Principles and Applications of Millimeter-Wave Radar*. Artech House, 1987.
- [4] Jerry Eaves and Edward Reedy. *Principles of Modern Radar*. Van Nostrand Reinhold Company, 1987.
- [5] S. Kay. *Modern Spectral Estimation*. Prentice Hall, Englewood Cliffs, 1988.
- [6] Karl Kluge and Charles Thorpe. Explicit Models for Robot Road Following. *Vision and Navigation: The Carnegie Mellon Navlab*. Kluwer Academic Publishers, 1990, Chapter 3.
- [7] D. Langer, J. K. Rosenblatt and M. Hebert. A Reactive System For Off-Road Navigation. In *Proc. IEEE Conference on Robotics and Automation*, 1994.
- [8] D. Langer and C. Thorpe. Sonar based Outdoor Vehicle Navigation and Collision Avoidance. *Proceedings IROS' 92*. Raleigh NC.
- [9] D. Pomerleau. *Neural Network Perception For Mobile Robot Guidance*. Kluwer Academic Publishers, 1993.
- [10] M. Rozmann, M. Lange, J. Detlefsen. Collision Avoidance Radar Using Wavefront Reconstruction. In *Proc. 3rd PROCHIP Workshop*, Paris, May, 14th 1990, pp 251-256.

Appendix A

FMCW Millimeter Wave Radar

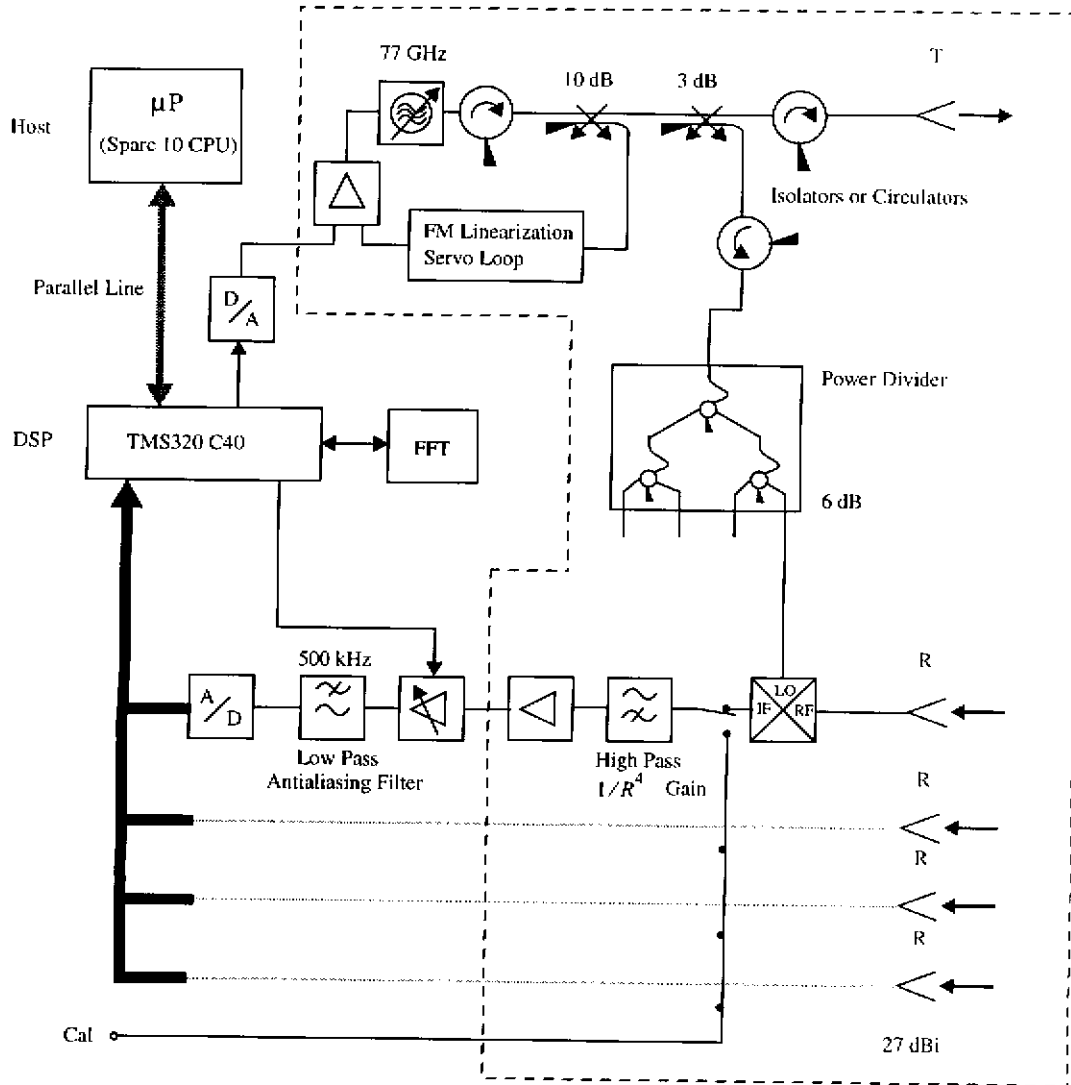

Appendix B

System Parameters and Technical Specifications for the FMCW Radar

Carrier Frequency	76.5 GHz
Modulation Waveform	FMCW
Swept Frequency	300 MHz
Range Coverage Resolution Accuracy	1 - 200 m 1 m 0.1 m (or better)
Azimuth Coverage Resolution Nominal Accuracy	12° 3° 0.1°
Elevation Coverage	3°
Range Rate Coverage Resolution Accuracy	-32 to +32 m/s 0.2 m/s 3 m/s
Modulation Cycle Time	1 ms
Processing Time	~ 2 ms per target
Update Rate	20 Hz (configurable to 70 Hz for single target)
Target Tracking	Yes
Antenna	1 Transmitter, 4 Receiver linear array V FoV: 3° , H FoV: 12° for each Antenna
Scanning Mechanism	Wavefront reconstruction by spectral analyses. Angular resolution cell: 3° x 3°
Primary Power	~ 100 W
Transmit Power	30 mW
Data Interface	RS-232 and optionally 8 bit parallel

Appendix C

Minimum turn radius that keeps vehicle within FoV of sensor

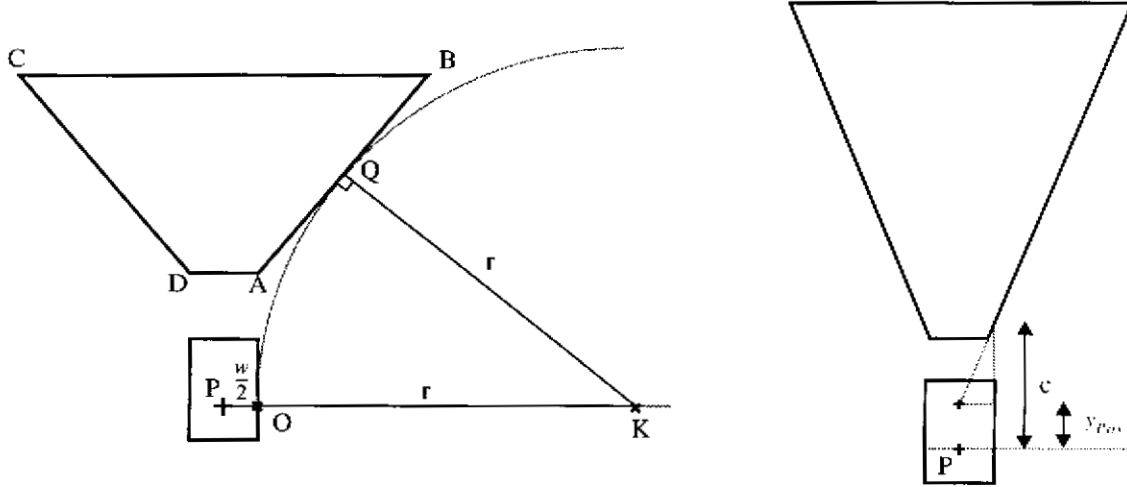

The sensor is assumed to be mounted in the centre of the vehicle. The minimum turning radius r_{min} is then given by the following equations, where y_{pos} is the offset between sensor origin and vehicle origin P , w is the vehicle width, HFoV is the horizontal field of view, m is the slope of the boundary line of the sensor field of view and c the corresponding intercept. For simpler calculations the origin is taken at point O :

$$m = \tan\left(90 - \frac{\text{HFoV}}{2}\right) \quad (1)$$

$$c = y_{pos} + \frac{w}{2} \tan\left(90 - \frac{\text{HFoV}}{2}\right) \quad (2)$$

$$r_{min} = \frac{w}{2} + mc + c\sqrt{m^2 + 1} \quad (3)$$

Using the dimensions of the Navlab vehicle and with HFoV = 12°, we get

$$r_{min} \approx 257 \text{ m}$$

The following values were used for the above calculation: $w = 2.5 \text{ m}$ $y_{pos} = 1.5 \text{ m}$

Maximum road gradient



If the vertical field of view of the sensor $\text{VFoV} = 3^\circ$ and the sensor is mounted at a height $z_{pos} = 1$ m above the ground, then the maximum gradient of the road that would still allow the sensor to see a target at $R = 200$ m is given by,

$$h = z_{pos} + R \cdot \tan \frac{\text{VFoV}}{2} = 6.2 \quad (4)$$

which means that the gradient would be about 3.1 % .

Geometric Analysis of different traffic scenarios

From the traffic scenario shown in Figure 8a, suppose that vehicles B and C are at 100 m distance from vehicle A and we assume the lane width to be 4 m. Then in order to resolve vehicles B and C as two point targets, we need to be able to resolve an angular bearing of $\text{atan}(4/100) = 2.3^\circ$.

From the traffic scenario shown in Figure 8b, we want to determine the radius of the curve that would place a vehicle B in the driving lane instead of the adjacent lane. We assume that the curve starts 19 m ahead of vehicle A, where the sensor's field of view just covers an entire lane.

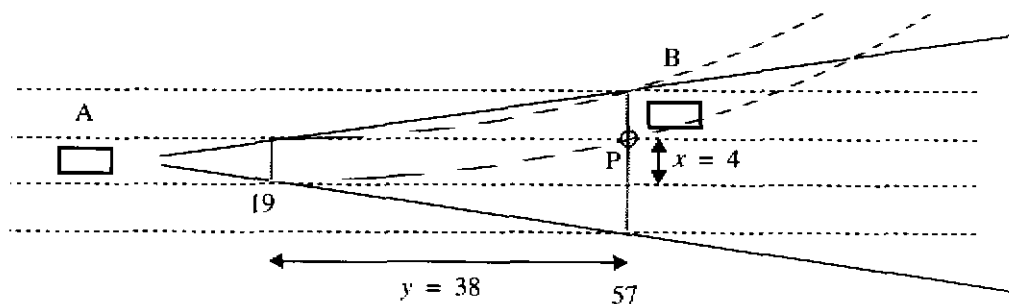

If we place the centre of the curve at $(R, 0)$ and use the equation of a circle at point P, then the radius R of the curve is given by:

$$R = \frac{x^2 + y^2}{2x} = 182.5 \text{ m}$$